

CF series cabs

Exterior



The styling of the DAF CF cab clearly shows its genuine DAF origin.

The tapered shape was not only chosen to give the cab its elegant lines.



It also highlights the well-considered design of a cab, tailored to a wide variety of applications, ranging from (inter)national and regional transport to refuse collection and heavy-duty work in the building industry.

A small cab front width means maximum safety in dense traffic and easy manoeuvring in confined areas like city court-yards, farm yards and construction sites.

The full 2.50 m width over the mudguards gives an optimum aerodynamic fit with the superstructure or semi-trailer.

The CF cab is a true workhorse, designed to survive in the toughest working environments.

A thick steel bumper protects the lower body panels and the lamps from light accidental damage.

Besides, these panels are to a large extent shatter and crash resistant, whereas the headlamps and direction

indicators are covered by virtually unbreakable Lexan lenses.



The robust cab design keeps downtime low, reduces the inevitable damage

repairs to a minimum and preserves the sound appearance of the vehicle.

The DAF CF cab is all about low operating costs and high durability.

Three different cab variants are available: the Day Cab, the Sleeper Cab and the high-roof Space Cab.

The DAF CF series: the right cab configuration for every vehicle application.

CF series cabs

Dimensions

Day Cab

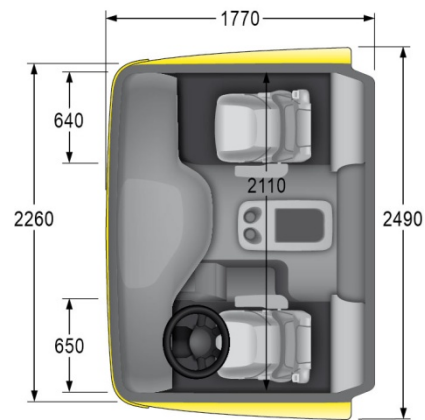
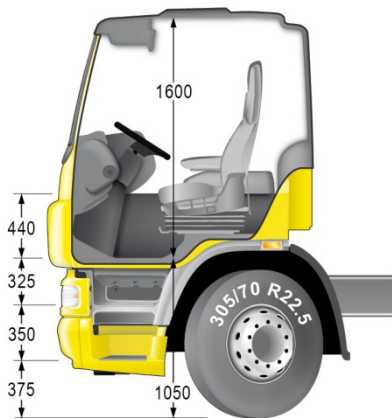

Sleeper Cab

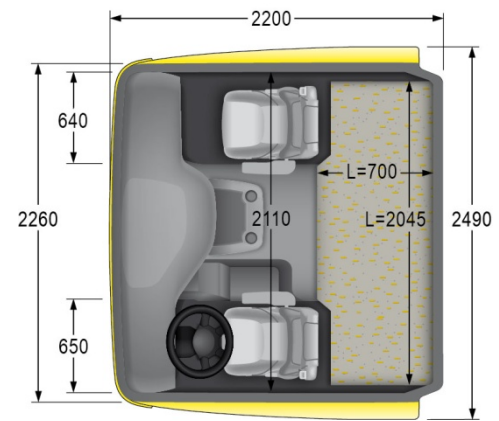
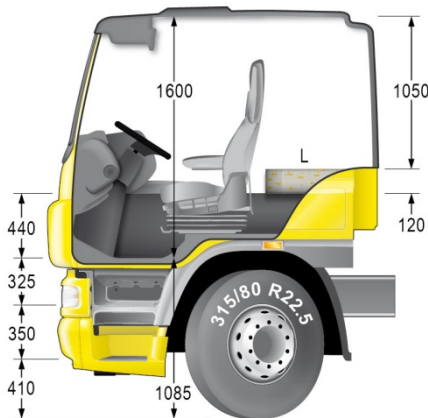

Space Cab

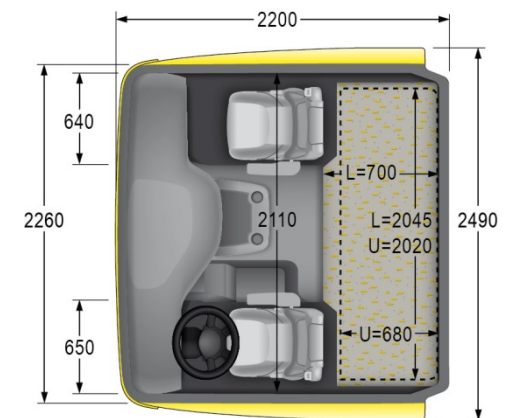
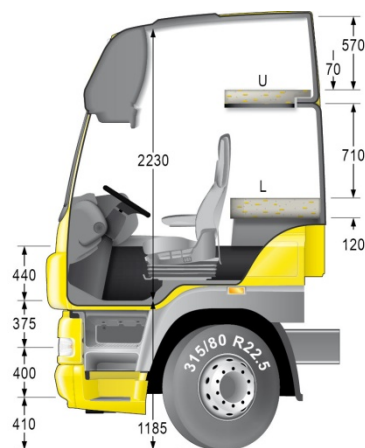

Step heights as drawn on Day Cab and Sleeper Cab related to CF65 and CF75 series. Step heights on Space Cab related to CF85 series.

CF series cabs

Interior



Creating the interior of a cab that will be used in a wide spectrum of completely different applications, is one of the most difficult tasks a designer may endeavour.

On the one hand it should offer first class comfort and luxury styling, on the other it should keep its quality appeal after years of hard service and numerous cleanings.

These are the conditions where a careful choice of materials and colour setting is the most important.

Get into the cab and you will immediately recognize the versatility of the well-succeeded cab concept.



The low cab floor eases frequently getting in and out, while the flat-topped engine tunnel still enables good cross-cab access.

The interior width allows for a third seat in the Day Cab without compromising on the driving comfort.

The class leading internal height, both for the normal roof (1.60 m) and the high-

roof (2.23 m) versions intensifies the overall feeling of space.

Comfortable seated behind the adjustable, soft-grip steering wheel, you will directly feel at home.

All controls on the cockpit-like dashboard are neatly arranged and within easy reach of the driver. Efficient heating, ventilation and insulation keep the cab interior comfortable and quiet. An excellent outside visibility completes the environment for safe and relaxed driving.

Ample storage space is available above the windscreen, on the engine tunnel and on the dashboard.

The sleeper cab variants offer large storage spaces underneath the lower bunk, including an airtight box (only accessible from the outside of the cab) or even a refrigerator tray (option).

The standard sleeping accommodation, in the good DAF tradition with a 2 m long one-piece mattress, is more than adequate for longer journeys.

The optional 150 mm thick pocket sprung Xtra Comfort mattress offers the driver the best sleep he may wish.



CF series cabs

Specifications

Exterior / Interior / Option	Day Cab	Sleeper Cab	Space Cab
Exterior:			
Cab suspension mechanical	•	•	•
Heated mirrors	•	•	•
Front view mirror	•	•	•
Halogen headlamps with Lexan lenses	•	•	•
Anti-theft system	•	•	•
Steel bumper	•	•	•
Interior:			
Electrical operated windows	•	•	•
Alarm system	•	•	•
Lower bunk	-	•	•
Accessory connector	•	•	•
Storage space	130 litres	380 litres	900 litres
Pollen filter	•	•	•
Optional:			
Cab suspension air	•	•	•
Xenon headlamps	•	•	•
Combi lights in the bumper	•	•	•
Skylights	-	-	•
Upperbunk	-	•	•
Pocket sprung lower bunk mattress Xtra Comfort	-	•	•
Third seat	•	-	-
Airbag driver and seat belt tensioners	•	•	•
Integrated handsfree telephone kit	•	•	•
Auxiliary heater / timer	-	•	•
Airco / automatic temperature control	•	•	•
Refrigerator	-	•	•
Sun visor	•	•	•
Storage box on engine tunnel	•	•	•
Dashboard trim wood structure	•	•	•
Audio equipment	•	•	•
External camera system	•	•	•
Coloured bumper + step	•	•	•

Depending on the vehicle configuration a specific option may not be possible. The availability and specification may differ per country. For further information please contact the DAF organisation. Subject to modification without prior notice.

CF series cabs

General details

Active safety

The active safety features incorporated in the DAF CF cab help prevent accidents or injury by optimising conditions for the driver and by making the vehicle perform more predictably in unexpected circumstances.

An alert driver in a comfortable environment is far less likely to be involved in an accident.

The well-insulated cab reduces noise and helps fight fatigue.

Options like air conditioning further contribute to the active safety of the vehicle and driver.

In addition, the DAF CF also includes the following active safety systems:

- Vehicle Stability Control (VSC) on tractors FT, FTG and FTP
- Anti-lock Braking System (ABS)
- Anti Slip Control (ASR)
- Electronic Braking System (EBS)
- Adaptive Cruise Control (ACC) and Forward Collision Warning (FCW)

Passive safety

Passive safety features built into the DAF CF help protect the occupants of the vehicle and other road users in the event of an incident. They include an integral steel safety cage as part of the cab structure. The cab design also comprises integral knee protection for drivers and co-driver.



Three-point safety belts and head rests are integrated in the driver and co-driver seats. A seat belt reminder system alerts a driver who drives off without being buckled up.

An airbag in the steering wheel, combined with seat belt tensioners, is optional.

Aerodynamics

Air management kits for the DAF CF improve aerodynamic efficiency and therefore reduce fuel consumption. The net result is more earnings per kilometre. They also enhance the overall appearance of the cab, and provide extra space for signage or company logos.

The air management options are available as complete kits or individually.



- Side skirts
- Roof spoilers
- Side collars

As genuine DAF options, the air management parts have been developed in a wind-tunnel together with the cab exteriors, and are guaranteed to fit.

Painting process

The high-quality durable finish protects the exterior of the vehicle for its full operational life, and helps maintain its value for a higher return on investment.

To obtain a highly corrosion-resistant finish to the cab, double-sided hot-dip galvanized steel is used for the inner and outer door panels, the cab rear wall and various brackets and sections in exposed areas.

The metal parts are then degreased and treated with zinc phosphate before receiving a cathodically applied primer followed by a filler coat.

The under body is treated to a PVC-based coating and then the entire cab is painted with a two-component polyurethane topcoat.

Finally, wax fluid is sprayed into box sections and cavities for extra corrosion protection.